

*Series 2200 Sliding Door
Operation and Maintenance Manual*

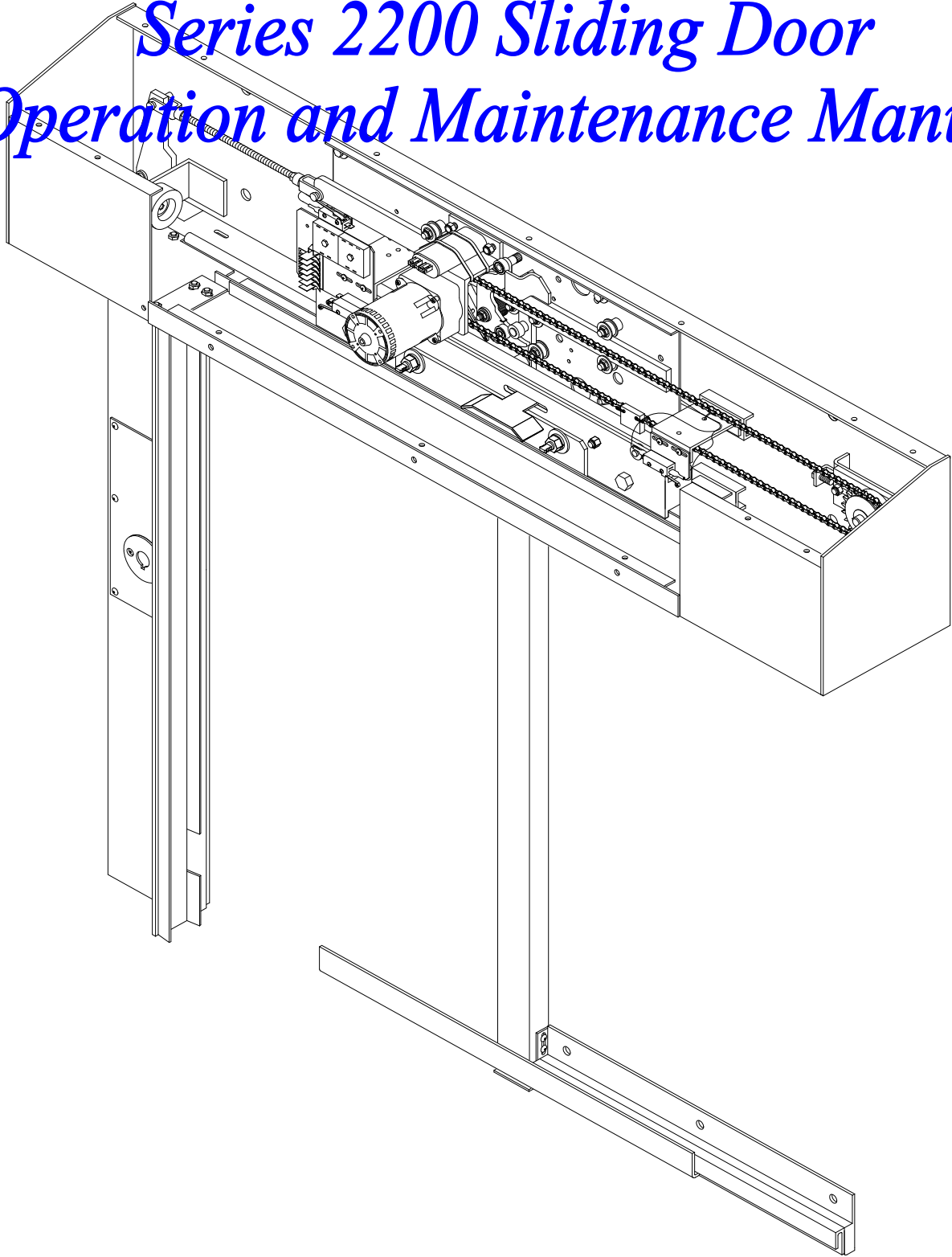

SERIES 2200

SLIDING DOOR OPERATORS

INSTALLATION INSTRUCTIONS

Refer to "**APPROVED**" *DDS DEVICE SUBMITTAL* for typical installation dimensions and locations.

Preparation - New Construction

The surface on which the *DDS Sliding Door Operator* is to be mounted should be free of excess mortar splatter, true to architectural dimensions and flat in respect to the door opening. If the Architectural Plans and Specifications require embedded steel plates for welding the *DDS Sliding Door Operator* in place, these embed plates are to be installed by the General Contractor prior to installation of the *DDS Sliding Door Operator* and must all be in the same plane. The *DDS Sliding Door Operator* can be bolted directly to the wall, but *DDS* recommends the use of embedded steel plates and welding these items securely to the wall. Any items located within harms way of the installation should be protected from damage.

Preparation - Existing Construction (retrofit)

All ceilings, floors, walls and glass should be protected from any damage that could occur during the demolition of the existing devices. Fans should be used to suck out all dust, smoke and fumes caused by demolition, preparation and installation of the new *DDS Sliding Door Operator*. If existing embeds are able to be used for the new installation it will be noted on the Architectural Plans and Specifications.

Layout

- A. To determine the bottom height of the *DDS Sliding Door Operator* use the door opening height from the Architectural Door Schedule + 7/8".
 1. Mark this height (above Finish Floor) at the *Lock Pilaster Column* side of the door opening, then use a precision leveling device to transfer this height towards the open side by twice the door width, then snap a line between the end marks (check this line for level).
- B. For *DDS Sliding Door Operator* that are bolted to the wall (not welded)
 1. To determine the bottom mounting holes height, snap a parallel line 3" above the bottom height line (check this line for level).
 2. To determine the top mounting holes height, snap a parallel line 10-1/2" above the bottom height line (check this line for level).
 3. To determine the center mounting hole locations
 - a. Determine the center-line of the *Rear Lock Tube*, then measure 4" from this center-line towards the open side of the *DDS Sliding Door Operator* and make a vertical line between the two horizontal chalk lines.
 4. To determine the left and right mounting hole locations
 - a. Measure the hole centers on the back of the *DDS Sliding Door Operator* then transfer them to the appropriate side making a vertical line between the two horizontal chalk lines.
 5. Use only high quality 5/8" x 4" concrete anchor bolts to fasten the *DDS Sliding Door Operator* to the wall. Make sure the mounting holes are drilled accurately.
- C. For *DDS Sliding Door Operators* that are bolted to the wall (top only) and welded at the bottom
 1. To determine the top mounting hole height, snap a parallel line 10-1/2" above the bottom height line (check this line for level).

DETENTION DEVICE SYSTEMS

Detention Equipment Manufacturer - Detention Equipment Contractor - General Contractor

Contractors License CA # 606042 B1, C61/D28 + WA # DETENDS074C3 CC01
25545 Seaboard Lane, Hayward, California - USA Phone (510) 783-0771 Fax (510) 783-5409

SERIES 2200

SLIDING DOOR OPERATORS

2. To determine the center mounting hole locations
 - a. Determine the center-line of the *Rear Lock Tube*, then measure 4" from this center-line towards the open side of the *DDS Sliding Door Operator* and mark on the horizontal chalk line.
3. To determine the left and right mounting hole locations
 - a. Measure the hole centers on the back of the *DDS Sliding Door Operator* then transfer them to the appropriate side marking on the horizontal chalk line.
4. Use only high quality 5/8" x 4" concrete anchor bolts to fasten the *DDS Sliding Door Operator* to the wall. Make sure the mounting holes are drilled accurately.
5. Make sure that the embeds installed by the General Contractor are in the same plane as the wall and are installed per the Architectural Plans and Specifications.

Device Housing

- A. Remove the *Cover Screws* open the *Transom Cover* to be able to remove the *Transom Access Panel* saving all the hardware for re-installing.
- B. Tack weld and/or fasten the *Device Housing* exactly as shown on this drawing, paying particular attention to the *Device Housing* being level from left to right and front to back.

Lock Pilaster Column

- A. Tack weld the *Lock Pilaster Column* in place exactly as shown on this drawing, paying particular attention to keeping the it perpendicular and square to the transom.

Rear Lock Tube

- A. Remove the hairpin from the pin at the top of the *Lock Bar*.
- B. Slide the *Rear Lock Tube* assembled with the *Lock Bar* (pin facing towards you) up through the 1 1/4" X 1 1/2" rectangular hole centrally located at the bottom of the *Device Housing*.
- C. With the *Lock Bar* in place push the *Rear Lock Tube* up to the *Device Housing*, check that it is perpendicular to the transom and tack weld in place paying particular attention not to get any weld splatter on the *Lock Bar*.

Wall Guide

- A. Install the *Wall Guide* exactly as shown on the drawing holding the dimensions and it must remain parallel with the *Device Housing*. Be sure not to burn through the *Door Lock Tube* while welding the *Wall Guide* as this will cause the *Lock Bar* to not function properly.

Door Hanger and Guide

- A. Install the *Door Hanger* and *Bottom Door Guide* exactly as shown. Pay particular attention to the dimensions on the drawing as they must be welded true to the back plane of the door.

Finish Welding

- A. Check all of the installed components for dimension accuracy

SERIES 2200

SLIDING DOOR OPERATORS

- B. Weld in strict accordance with the Architectural Plans and Specifications
- C. Clean all weld splatter, dress welds and touch up primer.

Locking Device

- A. Make sure the *Door Position Switch and Limit Switch* are moved up as far as possible to avoid damage to the switches during installation of the *Carriage Assembly*.
- B. Install the *Locking Device Assembly* (make sure that the door numbers match) using the (4) *Back Plate Bolts* and (4) *Back Plate Washers*.

Door Open Switch

- A. Make sure the *Limit Switch* are moved up as far as possible to avoid damage to the switches during installation of the *Carriage Assembly*.
- B. Install the *Door Open Switch Assembly* as shown on the drawings using the screws supplied on the transom mount.
- C. Run the wires through the "U" shaped switch mount on the back transom plate and secure them out of the way of any moving parts.

Carriage Assembly

- A. Install the *Carriage Assembly* (make sure the door numbers match) as shown on the drawing.

Door

- A. Install the door on the *Carriage Assembly*.
- B. Snug the 1/2" nuts up on the *Eccentric Door Hanger Bolts* but not tight enough that you can not adjust the door.
- C. Adjust the door so that it lines up with the *Rear Lock Tube* and the *Eccentric Door Hanger Bolts* are as close to center height as possible. Now tighten the 1/2" nuts.
- D. Move the door open to closed a few times to make sure there are no obstructions and the door travels freely with out binding.

Door Receiver

- A. The notch at one end of the *Door Receiver* is to be placed at the bottom towards the back of the operator. Do not deviate from the clearance dimensions at the top of the *Door Receiver* as this is required to clear the *Access Cover*.
- B. Make sure that the door mates with the *Door Receiver* leaving equal space on both edges. Now tack the *Door Receiver* to the *Lock Pilaster Column*. Open and close the door a few times to assure the proper fit, then finish welding per the Architectural Plans and Specifications.

Pilaster Lock

- A. Remove the *Access Cover* located on the front of the *Vertical Lock Pilaster Column*.
- B. Install the *Cleavis Mount* supplied to your lock with the bolts supplied.
- C. Attach the *Cleavis Linkage* supplied to the *Pivot Assembly* located in the transom above the *Vertical Lock Pilaster Column*.

SERIES 2200

SLIDING DOOR OPERATORS

- D. Now attach the *Yoke Assembly* to the *Lock Cleavis Mount Assembly* and bolt up the deadlock.

Final Adjustments

- A. Check the adjustment of the door hanger so that the door travels freely throughout the entire travel.
1. Make sure that the door is adjusted parallel with the rear lock tube.
- B. Next adjust the gear lash pressure by using the motor lock plate.
- C. Next make sure that while applying a light drag to the door during travel that the *Cam Follower* stops approximately 1/8" beyond the upper *Dead Lock Bar*.
1. If it doesn't stop correctly adjust the door travel limit switch to make it stop correctly.
- D. Next adjust the door position in relation with the rear deadlock rod.
1. If the *Dead Lock Bar* is not properly seated with the *Bottom Door Guide*.
 - a. Loosen the door hanger bolts and by using a pole clamp move the door until the Dead Lock Bar just drops into place, then move the door and additional 1/8" to assure that it is in the center of the slot on the Door Bottom Guide.
- E. Adjust the *Cleavis Linkage* with the deadlock in the up position so that the *Pivot Assembly* hole at the *Yoke Assembly* is positioned 5/16" above the centerline of the *Pivot Bolt*.
- F. Move the *Unlock Master Bar* to the door opened side as far as possible.
- G. Now attach the *Pivot to Master Bar Linkage* to the *Pivot Assembly*.
1. Then adjust the Yoke Assembly and attach the *Unlock Master Bar*, this should slip on freely without moving either part.
 2. Try the Paracentric Lock a few times making sure the motor and dead lock release freely .
- H. Install the Transom Access Panel with the Transom Access Panel Bolts & Nuts supplied.
- I. Adjust the Limit Switch so that it just makes contact (audible click) when the Lift Pivot is in the full deadlock position.
- J. Adjust the Motor Cutoff Limit Switch so that it just makes contact (audible click) when the Unlock Master Bar touches it. Be sure that the switch lever is not touching the switch body.
- K. Adjust the *Drive Chain* so that there is approximately 1/2" up and down movement.
- L. Adjust the *Clutch Torque Limiter* so that it takes approximately 40 - 45 lbs of pressure on the door to make it slip.
- M. Electrical Hookup
1. Refer to the Wiring Diagram on the Submittal Drawings for the factory wiring of the limit switches and motor.
 2. Secure all lines at completion to the *Access Cover* with the nylon wire ties supplied.
 3. Try the door a few times under power until you are satisfied with the operation.
- N. Secure the device by using the *Cover Screws* supplied to securely fasten the *Housing Cover* to the transom.

Optional Components

- A. See Approved Submittal for drawings and instructions

Special Electrical Components

SERIES 2200 SLIDING DOOR OPERATORS

A. See Approved Submittal for drawings and instructions

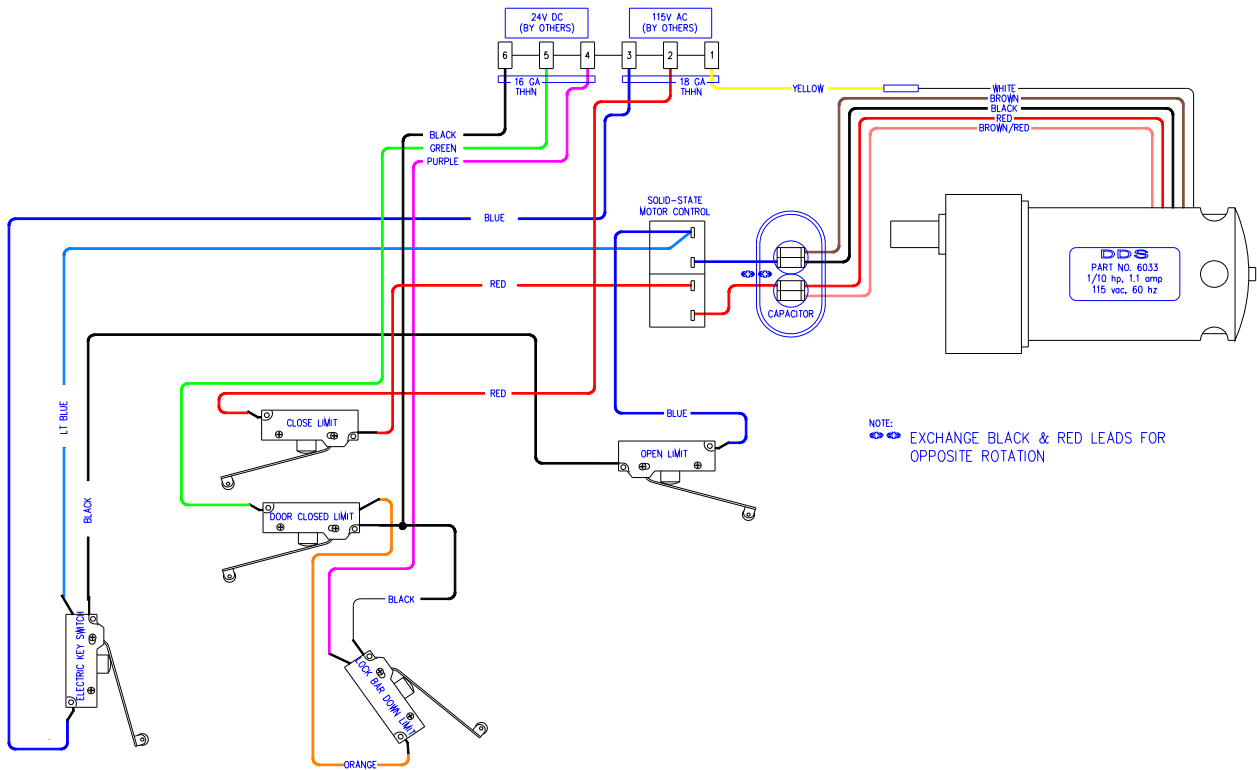

Wiring Diagram

The wiring diagram in the Submittal Package represents the wiring hook up for all standard *Series 2200 Sliding Door Operators*, if your facility has operators with non-standard conditions they will be referenced in the Submittal Package.

SERIES 2200

SLIDING DOOR OPERATORS

SPECIFICATIONS

Series 2200 Chain Drive Corridor Device

- A. Entry and Vestibule Door Operation Device – Door weight not to exceed 350 lbs
1. Housing unit entry and vestibule doors for Level III and Administrative Segregation Housing Units shall have fully automatic sliding doors with functions and components as follows:
 - a. Unlock, open and lock open by electric switch, a 36 inch wide door in not more than eight seconds.
 - b. Unlock, close and deadlock closed, by electric switch, a 36 inch door in not more that eight seconds.
 - c. Stop the movement of any door in mid-travel, so that it may be moved by hand in either direction by applying approximately 35 pounds of force on the door. A free wheeling door will not be accepted.
 - d. Instantly reverse the direction of movement of any individual door.
 - e. When a door is blocked and blocking object is removed, the door shall automatically continue movement to the open or closed position if switch is still depressed.
 - f. Sally port or vestibule doors shall be interlocked so that only one door can be opened at a time using electric controls. Interlocking circuit shall be provided at Control Console under provisions of Division 17.
 - g. Force exerted by the door in travel shall be 35 to 50 lbs., adjustable by clutch.
 - h. Each door deadlocks closed at two concealed points at the rear of the door.
 - i. Individual doors may be unlocked mechanically and may be operated electrically from both sides of the door by the same paracentric key.
 - j. Each door has a limit switch at the closed end and rear deadlock to provide status indication. A red a light shall indicate unlocked status, a green light shall indicate closed and locked.
 2. Components
 - a. Motors are 1/10 HP., single phase, 120v,60 Hertz U.L. listed as manufactured by General Electric or equal. Motor draws no more than 1.5A under full load current. Motor is thermal protected with automatic reset feature. Motor is controlled by a solid state device that does not allow the motor to instantly reverse direction without coming to a complete stop.
 - b. #41 chain, sprockets and gear reducers are by a nationally recognized manufacturer.

DOOR DEVICE TRANSOMS, COVERS, COMMON COMPONENTS

- A. Door Device Transoms and Covers
1. Horizontal Transoms: Sliding door mechanisms are constructed from 3/16 inch steel plate. Transoms are either rectangular or sloped as required. Mezzanine level transom tops are sloped 26 degrees. Transom covers are 10 gauge steel sheet. All openings in transoms are baffled, including bottom slot for hanger to prevent wires or contraband from entering the transom.
 2. Transom Covers: Non-removable and hinged to the track box and secured with security screws.
 3. Wire Tray: Is in transom.
 4. Transom Back Plate: Is factory punched for anchor bolts.

SERIES 2200

SLIDING DOOR OPERATORS

5. Paint: Entire inside and outside of transom except track, rollers and drive mechanism is painted with rust inhibiting primer.

B. Components

1. Vertical Lock Bar Cover: Is constructed of 10ga steel sheet. The vertical lock bar cover is removable only when transom cover and door has been removed.
2. Door Hanger: Is constructed from 1/4 inch steel plate, 75% of door width. Door hanger interlocks with transom baffle 1/4 inch.
3. Door And Wall Guide: Is constructed from 3/16 inch thick steel. The guides overlap a minimum of one inch vertically and four inches horizontally at any position of travel. There is 1 inch contact between stainless steel lock bar and door guide. Clearance between lock bar and guides is no more than 1/8 inch on either side and top to bottom.
4. Hanger Support Rollers: Turned from solid alloy steel, 2-3/4 inches OD. grooved 3/8 in deep to engage 5/8" diameter cold rolled steel track.
5. Hanger Support Rollers have anti-friction ball bearings with hardened members and grease shields on both sides.
6. Hanger Support Roller Studs: High alloy steel, heat treated and a self-locking nut.
7. Door Hanger Adjuster studs: High alloy steel, heat treated, with eccentric bushing for adjustment and a self-locking nut.
8. Door Bumpers: Heavy duty 2-1/2" diameter rubber bumpers, to quiet and cushion the door at each end of travel.
9. Door Receiver: Is made from 10ga steel 1 inch deep.

ELECTRICAL WORK

A. Factory Wiring

1. Provide internal wiring and final connections within the transom of sliding door devices.

B. The following is specified in Divisions 16 and/or 17.

1. Monitoring and control conduit, wiring and final connections from the console to locks, switches, terminal blocks and all components of door control system.
2. Coordinating, furnishing and installing complete console system including panels, switches and indicator lights.
3. Furnishing and installing conduit and wiring from supply sources to each console, cut off switches, locking devices and other electrical equipment incidental to the power supply.
4. Connections to terminal blocks in housings of sliding doors and locks.
5. Providing terminal block diagrams to other Sections.
6. Provision for running different voltage wiring within common compartment.

FABRICATION - GENERAL

A. Factory assemble items where practicable, true to line and free of distortion of defects.

B. Welding

1. Steel and stainless steel components not plant fabricated shall be designed for field-welded connections.
2. Plug or stitch welds unless otherwise indicated.
3. Weld according to American Welding Society standards.

SERIES 2200

SLIDING DOOR OPERATORS

4. Remove excess welding slag, burrs and rough edges.
 5. Prime bare welds using job specified primer.
- C. Equipment is fully fabricated, assembled and finished, ready for final installation and as follows:
1. Work, including wiring, within transoms and emergency release cabinets for sliding doors is completed at the factory.
 2. Hardware (**when supplied by DDS**) that is essentially non-projecting shall be installed in doors and frames, at the factory, including the following:
 - a. Mechanical locks and their associated strikes, keepers and escutcheons.
 - b. Hinges, either screwed or welded, shall be fastened to the doors.
 - c. Flush pulls.
 3. Other hardware (**when supplied by DDS**) shall be field installed; including door receiver, rear lock tube assembly, door hanger, door guide and wall guide.
 4. The field installed hardware group for each opening shall be separately packaged, accompanying the doors and clearly identified with its opening.

SERIES 2200

SLIDING DOOR OPERATORS

PRODUCT WARRANTY

Warranty - Standard Products

DETENTION DEVICE SYSTEMS (DDS) warrants each standard product manufactured and sold by it to be free of defects in materials and workmanship for such period of time and under such conditions as are specified herein or as may be specified by DDS on the face of its quotation or otherwise reduced to writing and expressly approved by DDS. The warranty period so specified by DDS shall commence on the date of shipment from DDS to the original purchaser. If no period of time is stated, then DDS's Warranty for Standard Products is limited to one (1) year from the date of delivery.

Repair or at DDS's option, replacement of defective parts shall be the sole and exclusive remedy under warranty, provided that, DDS may, as an alternative, elect to refund an equitable portion of the purchase price of the Product, items expendable in normal use are not covered by this warranty. All warranty replacement or repair of parts shall be limited to Product malfunctions which, in the sole opinion of DDS, are due or traceable to defects in original materials or workmanship. All obligations of DDS under this warranty shall cease in the event of abuse, accident, alteration, misuse or neglect of the Product. In-warranty repaired or replacement parts are warranted only for the remaining unexpired portion of the original warranty period applicable to the repaired or replaced parts. After expiration of the applicable warranty period, Buyer shall be charged at the then current prices for parts, labor, and transportation.

Reasonable care must be used to avoid hazards. DDS expressly disclaims responsibility for loss or damage caused by use of its Products other than in accordance with proper operation procedures.

No warranty is provided by DDS for products sold hereunder which are not manufactured by DDS, but the manufacturer's warranty for such products, if any, shall be assigned to the Buyer without recourse to DDS.

THIS WARRANTY IS EXPRESSLY IN LIEU OF AND EXCLUDES ALL OTHER EXPRESSED OR IMPLIED WARRANTIES, INCLUDING BUT NOT LIMITED TO WARRANTIES OF MERCHANT ABILITY AND OF FITNESS FOR PARTICULAR PURPOSE, USE, OR APPLICATION, AND ALL OTHER OBLIGATIONS OR LIABILITIES ON THE PART OF DDS, UNLESS SUCH OTHER WARRANTIES, OBLIGATIONS OR LIABILITIES ARE EXPRESSLY AGREED TO IN WRITING BY DDS.

Warranty - Expendable Products

DDS warrants that at the time of delivery expendable items or Products manufactured and sold by it hereunder are free of defects in material and workmanship and conform with DDS's specifications or other specifications expressly agreed to in writing by DDS, **BUT DDS SHALL HAVE NO OTHER OR FURTHER RESPONSIBILITY THEREFORE, WHATSOEVER, AND DDS DISCLAIMS IMPLIED WARRANTIES OF MERCHANT ABILITY AND FITNESS WITH RESPECT THERETO.**

Authorized By _____ Date _____

SERIES 2200 SLIDING DOOR OPERATORS

PARTS LISTS

Note: When order parts for the following items, always refer first to the Door Number and the appropriate Part No.'s on the Bill of Materials. Some of the parts are sold as assembled items only.

Series 2200 General Assembly (L.H. as shown, R.H. opposite)

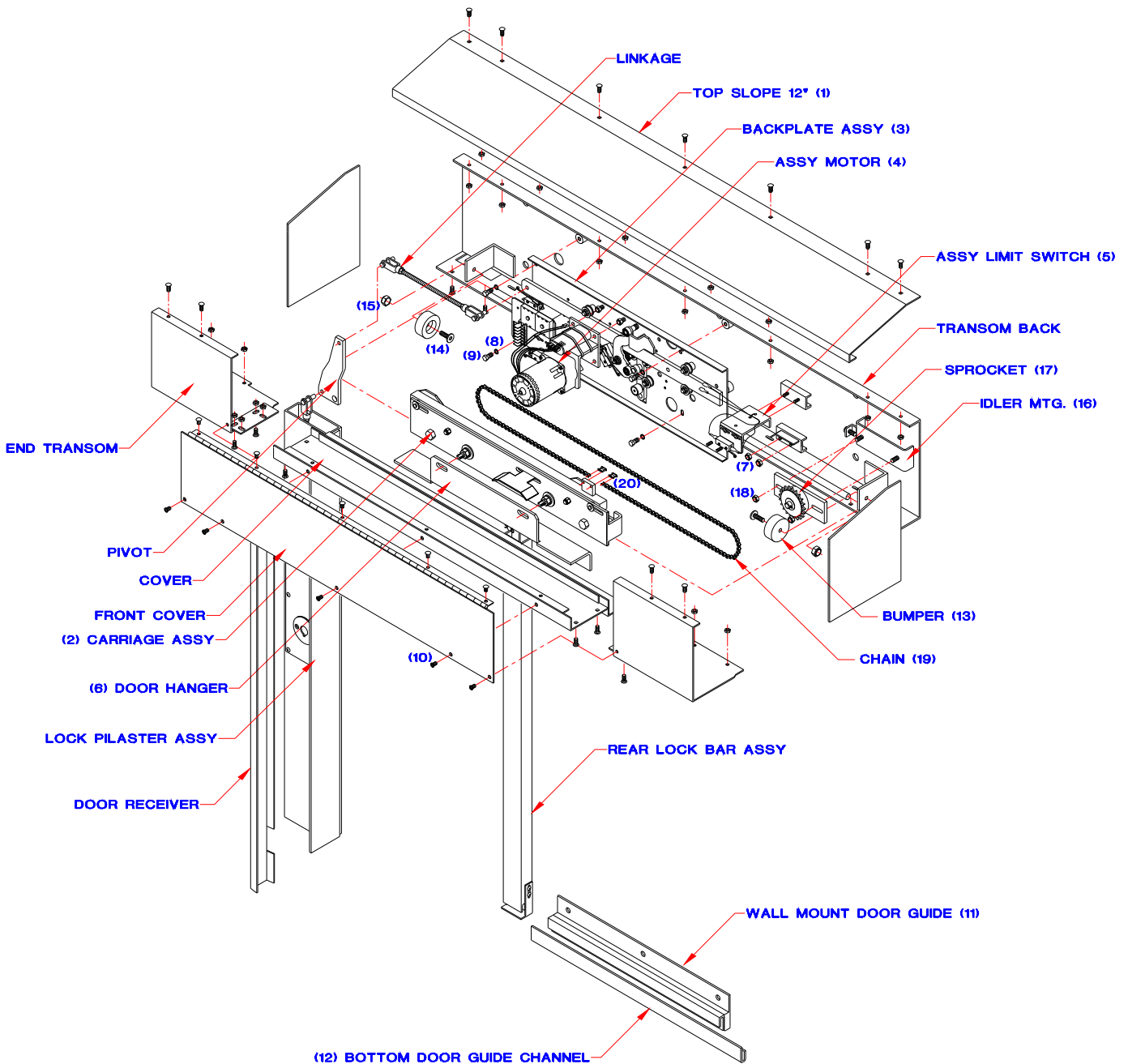

SERIES 2200 SLIDING DOOR OPERATORS

Carriage Assembly (L.H. as shown, R.H. opposite)

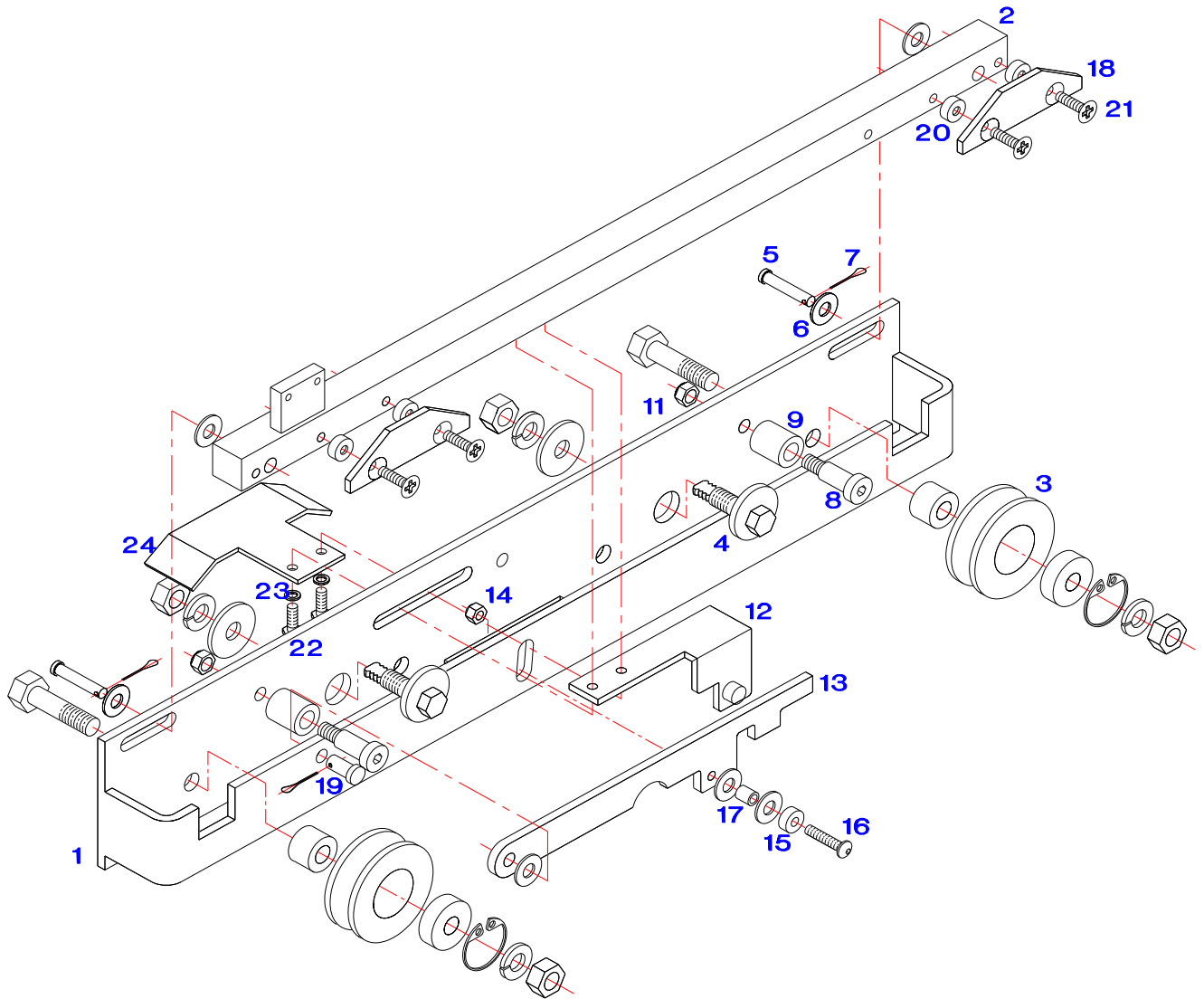

SERIES 2200 SLIDING DOOR OPERATORS

Locking Device Assembly (L.H. as shown, R.H. opposite)

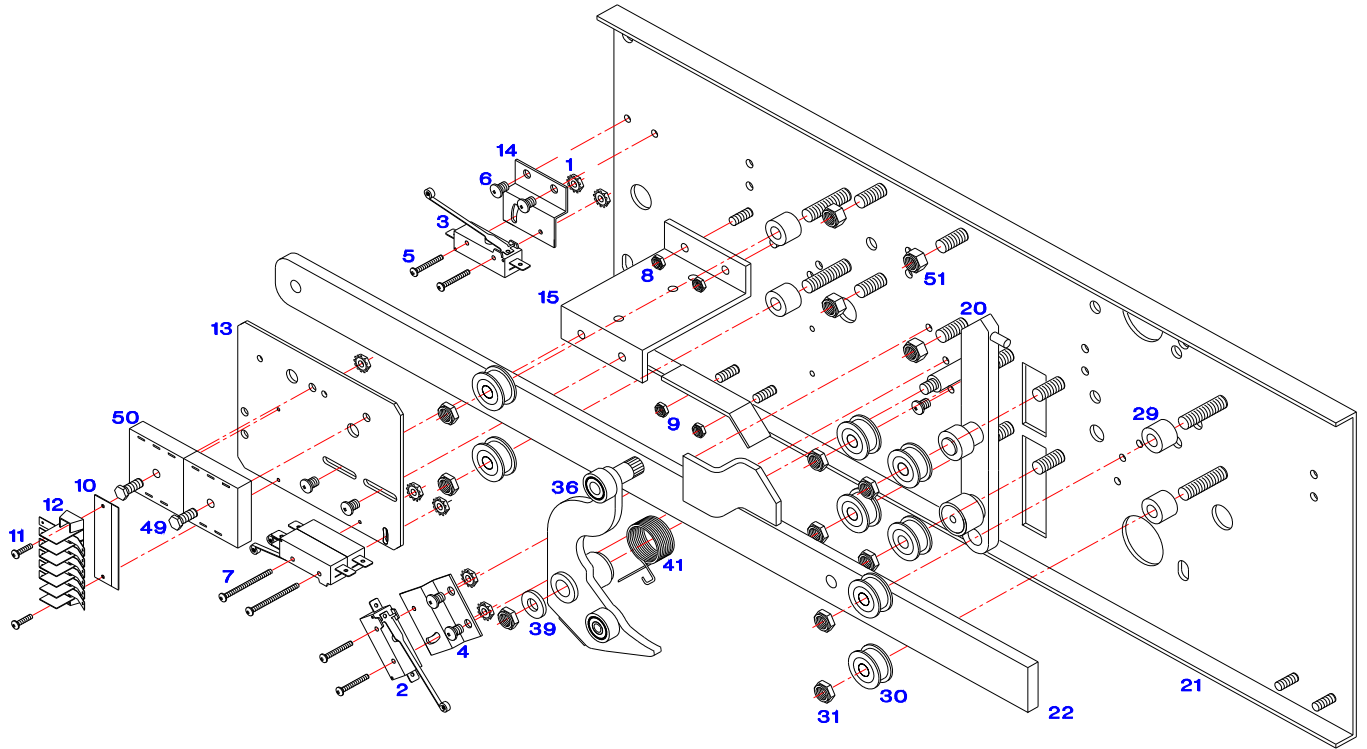

Door Open Switch Assembly (L.H. as shown, R.H. opposite)

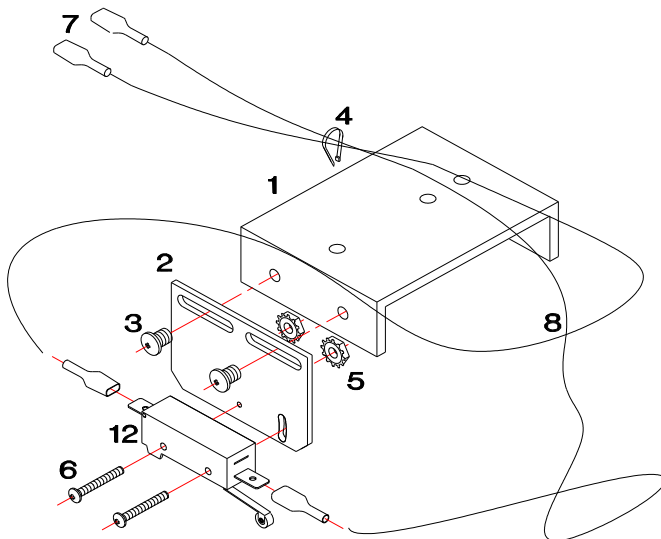

SERIES 2200

SLIDING DOOR OPERATORS

ADDITIONAL CONDITIONS

Maintenance - Every 12 Months

- Check for loose bolts
- Check wires for tightness and make sure they are not interfering with any moving parts
- Check for abnormal wheel wear
- Clean out any debris buildup

Adjustments - Non Factory

- All adjustments to the device are to be made by Certified Factory Technicians only, any adjustments by un-authorized personnel will Void Warranty.

FACTORY INFORMATION

Location

Detention Device Systems
25545 Seaboard Lane
Hayward, California 94545

Hours

8:00 AM to 4:30 PM Monday thru Friday except Holidays

Phones

(510) 783-0771
FAX (510) 783-5409 and (510) 785-4379

SERIES 2200

SLIDING DOOR OPERATORS

TABLE OF CONTENTS

INSTALLATION INSTRUCTIONS	1
Preparation - New Construction	1
Preparation - Existing Construction (retrofit)	1
Layout	1
Device Housing	2
Lock Pilaster Column	2
Rear Lock Tube	2
Wall Guide	2
Door Hanger and Guide	2
Finish Welding	3
Locking Device	3
Door Open Switch	3
Carriage Assembly	3
Door	3
Door Receiver	3
Pilaster Lock	3
Final Adjustments	4
Optional Components	4
Special Electrical Components	5
Wiring Diagram	5
SPECIFICATIONS	6
Series 2200 Chain Drive Corridor Device	6
Door Device Transoms, Covers and Common Components	6
Electrical Work	7
Fabrication - General	7
PRODUCT WARRANTY	9
Warranty - Standard Products	9
Warranty - Expendable Products	9
PARTS LISTS	10
Series 2200 General Assembly (L.H. as shown, R.H. opposite)	10
Carriage Assembly (L.H. as shown, R.H. opposite)	11
Locking Device Assembly (L.H. as shown, R.H. opposite)	12
Door Open Switch Assembly (L.H. as shown, R.H. opposite)	12

SERIES 2200

SLIDING DOOR OPERATORS

ADDITIONAL CONDITIONS.....	13
Maintenance - Every 12 Months	13
Adjustments - Non Factory.....	13
FACTORY INFORMATION	13
Location.....	13
Hours.....	13
Phones	13
TABLE OF CONTENTS.....	14
BILL OF MATERIALS	16